



INLINE
INLINE TENSIONED
MANUAL FOR ROLL-UP SCREENS

DIRECTORY

GENERAL INFORMATION	3
SAFETY INSTRUCTIONS	4
METHODS OF INSTALLATION	
QuickMount-Brackets	7
Mounting Plate	10
Universal-Mounting Brackets	11
Wall/Ceiling Brackets	12
Wall Brackets	13
Ceiling Brackets	14
Ceiling Case for ceiling integration	15
Ceiling Case with mounting set	15
Projection screen for ceiling Integration	19
Mounting set for suspended ceiling	19
ELECTRICAL INSTALLATION	22
STOP POSITION ADJUSTMENT	23
Motor left/fabric back and motor right/fabric front	24
Motor left/fabric front and motor right/fabric back	25
ACCESSORIES	26-27
MANUAL ROLL-UP SCREENS	
Crank mechanism	28
Spring-Roller mechanism with soft-rewind	28
TENSIONING UNIT	
Tensioning Unit INLINE	29
Tensioning Unit INLINE tensioned	30
DECLARATION OF CONFORMITY	31-32

GENERAL

ROLL-UP PROJECTION SCREEN INLINE

Roll-up screen INLINE is a permanently installed projection screen consisting of a roll-up tube that is attached to a drive system (asynchronous tube motor) on one side and pivoted on the opposite.

The drive and the bearing are mounted on lateral metal plates, which are mechanically connected to a two-part screen casing made of aluminum sheet (protective casing). The projection material is rolled up on the winding tube and has a weighting profile (bottom bar) at its lower end.

The winding tube maintains the height and the projection material is unrolled downwards.

Projection screen INLINE is used for displaying images, videos, films, etc. supplied by a projector. INLINE projection screens can be mounted to the ceiling or to the wall via a mounting bracket and installed in a suspended ceiling.

Detail information on the roll-up screen and the serial number VAT can be found on the type plate on the back of the screen material in the bottom left corner and at the top of the protective casing.

QUALITY AND SAFETY

The roll-up projection screen is in line with the applicable European guidelines and standards (incomplete excerpt):

Directive 2006/42/EC on Machinery

Low Voltage Directive 2014/35/EU

Electromagnetic Compatibility Directive 2014/30/EU

DIN 19045-2 Projection of still pictures and motion pictures - Part 2: Screens

DIN 56950-4 Entertainment Technology - Machinery Installations - Part 4: Safety requirements for serially manufactured projection screens

DIN EN 60335-1 and 2 Household and similar electrical appliances - Safety - Part 1: General requirements and Part 2: Special requirements

The screen material corresponds to a building material class in accordance with DIN EN 13501-1 or DIN 4102-1 and is in line with the limit values for waviness according to ÖNORM A 2115.

The general terms and conditions are available at www.AVstumpfl.com/agb.

WARRANTY

The roll-up screen INLINE may only be used as a projection screen.

No persons are allowed to stay in the operation area.

For all damages to persons and property which occur from inappropriate use the warranty will be invalid and the manufacturer cannot be held responsible.

The intended use also includes the observance of all instructions and information contained in this operating manual.

The warranty period for production deficiencies is 24 months. Please mind the guarantee regulations with media control panel operation on page 22.

UNAUTHORIZED MODIFICATIONS

Unauthorized modifications, built-on components and other changes to a INLINE roll-up screen or control element, without the prior express written consent of the manufacturer, will invalidate all liability and warranty claims.

CHANGING THE IMAGE HEIGHT - WARRANTY of FLATNESS

Each roll-up screen is set to the ordered picture height and the flatness is optimized for this image height. A guarantee claim for the flatness exists exclusively for the ordered image height.

Please note that a subsequent adjustment of the image height can lead to a change in the flatness!

NOTE

Always keep the manual close to the installation site! The manual must be accessible to the operator and for maintenance work.

SAFETY INSTRUCTIONS

TRANSPORT - MOUNTING



The roll-up screen must be secured during transport and assembly in accordance with the total weight. During lifting work, no person must remain in the danger zone below the suspended load (roll-up screen)! The load must be distributed evenly and secured against falling!

The total weight is displayed on the roll-up screen type plate or on the packaging. Always use a sufficiently high number of people in line with the total weight for transporting the roll-up screen. Make sure the roll-up screen is transported and assembled horizontally and torsion-free to prevent the safety brake from engaging.

MECHANICAL MOUNTING

NOTICE

Before assembly check the roll-up screen for transport damage! Information on how to proceed in cases of transport damage is provided on the info sheet IMPORTANT INFORMATION.



Before assembly make sure that the wall or the ceiling is able to carry the load. Choose the screws/ attachment material in accordance with the weight of the projection screen and the condition of wall or ceiling.

NOTICE

In order to ensure optimal flatness of the projection surface avoid assembly within the vicinity of radiators, ventilation and air condition systems. To ensure safe and trouble-free operation make sure that the roll-up screen is installed in an absolutely horizontal and torsion-free position!

It must also be ensured that there are no obstacles at a sufficient distance from the radius of action of the projection surface, so it can be rolled down and up unhindered. Damage caused by improper mounting, an incorrectly selected mounting position, modifications or built-on components are excluded from guarantee!

ELECTRICAL INSTALLATION



The electrical installation is to be performed by a trained electrician from a licensed expert company only. Please hand over this manual and the connection directions that are supplied separately with every motor or switch or control unit to the executing expert.

The electrical installation may only be carried out in a voltage-free state! Secure the system against unintentional reconnection! Make sure that all connection cables to be installed are de-energized and secure the unit against unintentional activation.

Prior to the installation check the isolation of the connecting cable and the cable feedthrough at the casing for damage. Check that there is no ohmic continuity between the connecting cable and the roll-up screen casing so that any danger by indirect contact is excluded. Control units must not be installed in the operating area of the roll-up screen.

FIRST-TIME OPERATION

NOTICE

When starting the roll-up screen for the first time secure the immediate area of the screen and its movement range. During first-time operation the screen should be moved in steps only. When there are signs of danger or danger situations roll-up screen operation must be stopped immediately. During the test run the operator must always have full and direct sight of the roll-up screen.

Remove the transport protection (protective film) and make sure that the bottom bar did not get stuck in the roll-up screen casing during transport or assembly and that the screen material can unwind without any problems!

OPERATION

⚠ CAUTION

The projection screen must only be operated in a well lit environment so as to recognize any danger situations that might occur. During operation the operator must always have full and direct sight of the roll-up screen so as to be able to stop it immediately when a danger situation occurs.

Supervision by adults is required when putting the roll-up screen into operation.

During operation the movement range and the immediate area of the roll-up screen must be secured. No persons are allowed below the roll-up screen!

Before winding up the screen check the bottom bar and the screen material for damage and remove any possible obstacles within the movement range. No additional loads must be attached to / or lifted by the bottom bar.

In the case of recognizable damage to the roll-up screen it must immediately be taken out of service. It can only be put back into service after being repaired and checked/cleared for use by an expert.

MAINTENANCE TIPS - CLEANING

⚠ CAUTION

During work at the roll-up screen make sure that it cannot be started accidentally.

Protect the screen material from soiling. If necessary clean it with a slightly damp and soft cloth. Do not use any aggressive cleaning agents, such as acetone, turpentine, cellulose thinners or ethyl alcohol or similar substances.

MAINTENANCE

Drives, bearings and other rotating parts of the roll-up screen are permanently lubricated and are maintenance-free. The roll-up screen must be protected from soiling. Maintenance and repair work must only be carried out by authorized experts.

NOTICE

SAFETY INSPECTION

INLINE roll-up screens must undergo annual visual inspection and control run.

An annual safety inspection is not mandatory.

In case of visible damage or unusual noises during the operation the roll-up screen must immediately be taken out of service. It must only be returned to service upon successful repair and inspection/clearance for use by an expert.

WARNING

DISASSEMBLY

For disassembly the same safety instructions apply as listed for TRANSPORT - ASSEMBLY on page 4.

DISPOSAL

At the end of its lifetime this product must not be disposed of with normal household waste but needs to be taken to a collection site for recycling.

Disassembly of a INLINE roll-up screen takes a few steps only and by separate disposal of the waste you can make an important contribution towards environmental protection. In separated form the materials can be recycled.

Casing components and bottom bar are made of aluminum and the lateral brackets are made of steel.

For the projection screen material refer to the type plate.

The motor drive is to be disposed of at a collection center for electric devices.

Contact your local disposal company for the address of a collection center.

QUICKMOUNT-BRACKETS

inline 90^{bm} inline 125^{bm}

inline tensioned 125^{bm}

INLINE 090 and INLINE 125 come with QuickMount brackets, as a standard.

The two QuickMount brackets can be attached either to the wall or to the ceiling.

Use four screws which are appropriate to the weight of the screen and the quality of the wall.



WALL MOUNTING



CEILING MOUNTING

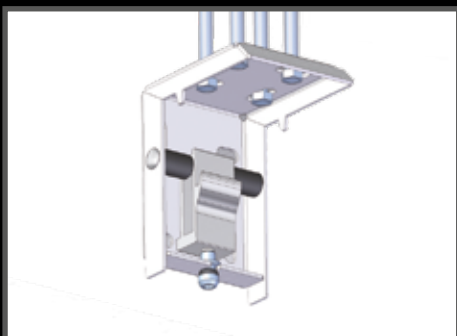
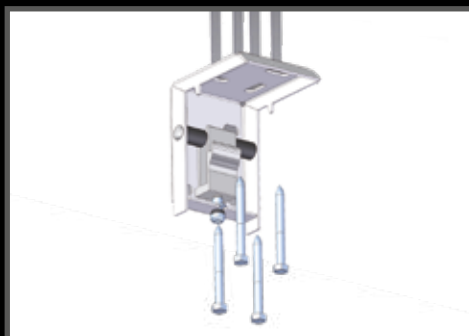

SYSTEM COMPONENTS

The QuickMount bracket consists of following main components:

- QuickMount bracket (grey)
- Hook profile (red)
- Locking screw (yellow)

(sketch showing hook profile in locking position)

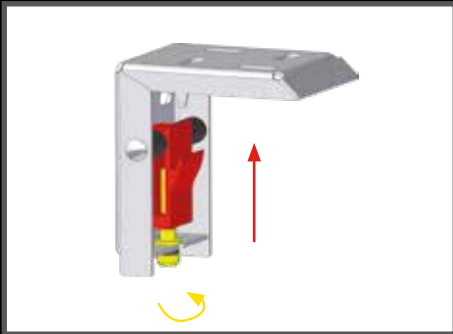

FUNCTIONAL PRINCIPLE

The screen casing is hooked onto the hook profile (red), which can be moved upwards by the locking screw (yellow) to secure the mounting.

(sketch showing hook profile in open position)

It is recommended that the QuickMount brackets are positioned on each side within the first fifth of the screen width. (0,2x WIDTH)

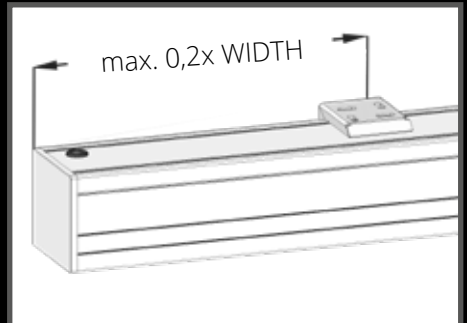

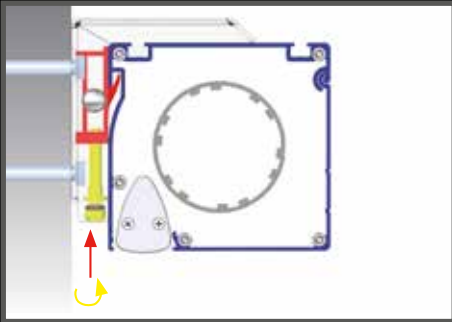
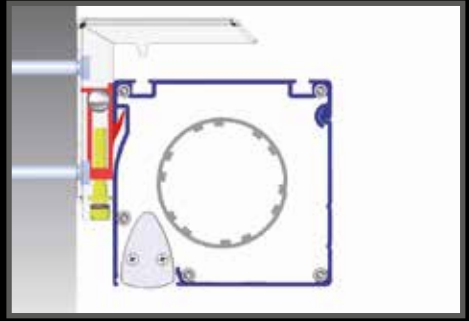
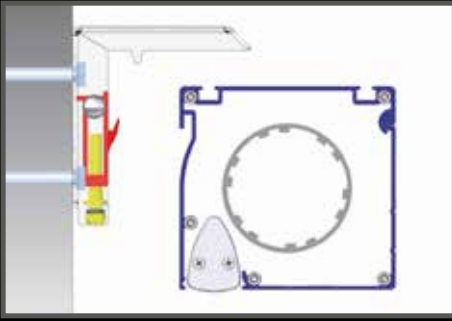

The screen casing (blue) has to be hang up at the rear recess onto the hook profile (red).

- QuickMount bracket (white)
- QuickMount sliding hookprofile (red)
- Screen casing (blue)
- Locking screw (yellow)

The casing must be lifted towards the upper horizontal part of the QuickMount bracket by turning the locking screw clockwise, until the safety wedge of the bracket fits into the upper T-slot in the casing.

NOTICE

The locking screw must be tightened with low force to avoid deformation of the casing. Max.torque 3Nm.



MOUNTING PLATE

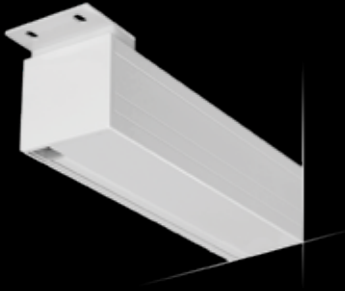

inline 90™ inline 125™

inline tensioned 125™

INLINE 090 and INLINE 125 can be optionally delivered with mounting plates for ceiling mounting

The two mounting plates and the distance elements have to be attached at either sides of the screencasing with the 2 enclosed countersunk screws and the square nuts M5. (see sketches below)

If necessary, the distance element can be rotated 180 ° to put the motor cable to the left.

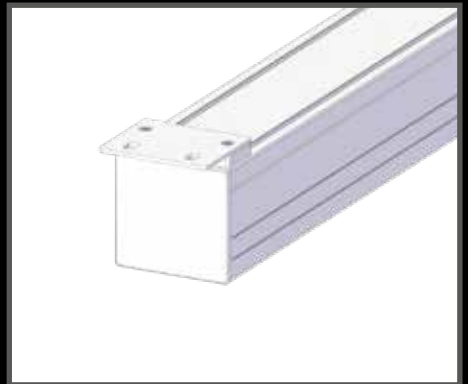
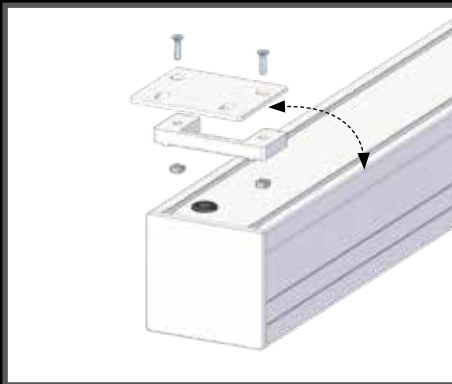

UNIVERSAL MOUNTING BRACKETS



INLINE 160 is delivered with universal mounting brackets, as a standard.
(optional for INLINE 090 and INLINE 125)



The two mounting brackets have to be attached at either sides of the screen casing with the 4 enclosed Phillips screws. Depending on where the projection screen is mounted to (wall or ceiling), the brackets have to be attached horizontal or vertical. (see sketches below)

WALL MOUNTING

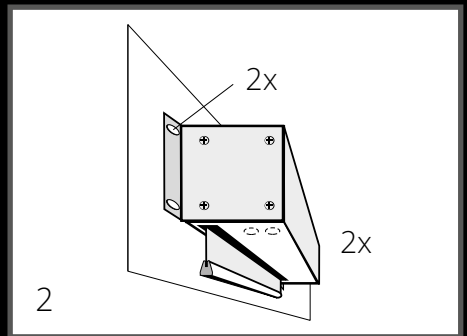
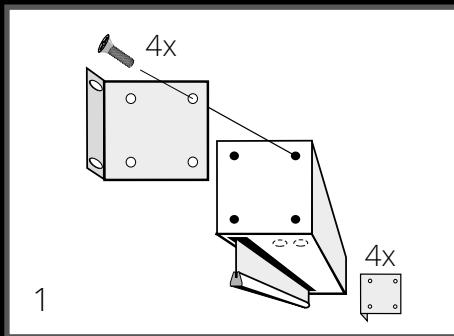

CEILING MOUNTING

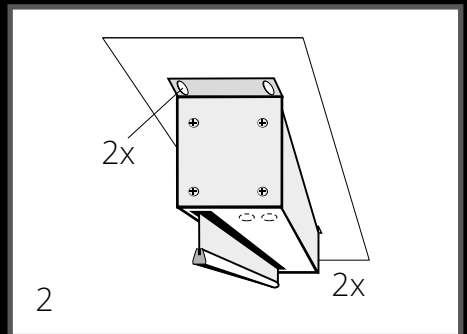
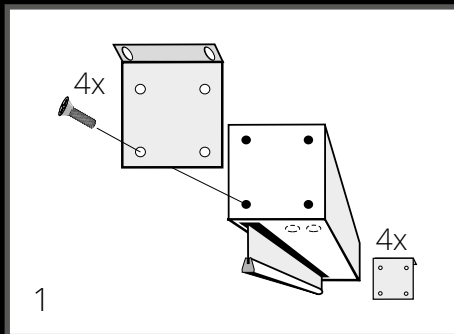

WALL / CEILING BRACKETS

inline 90sm inline 125sm inline 160sm

inline tensioned 125sm

inline tensioned 160sm

The INLINE-wall/ceiling bracket can be used for wall or ceiling mounting because of its horizontal and vertical mounting option.

Available for INLINE 160 (optional for INLINE 090 and INLINE 125)

The two wall/ceiling brackets have to be attached at either sides of the screen casing with the 4 enclosed Phillips screws. Depending on where the projection screen is mounted to (wall or ceiling), the brackets have to be attached horizontal or vertical. (see sketches below)

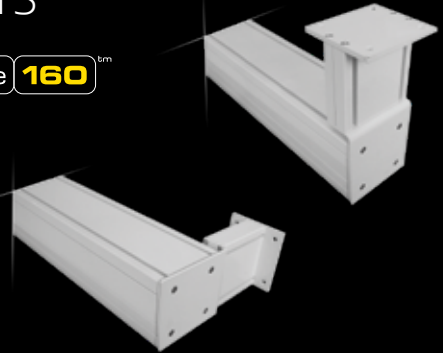

WALL MOUNTING

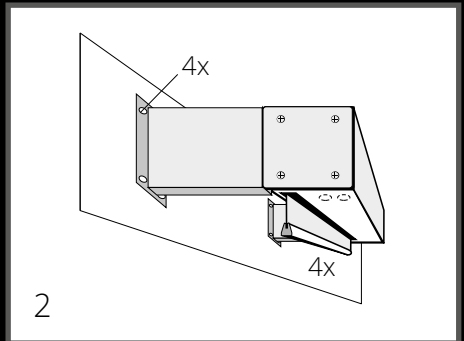
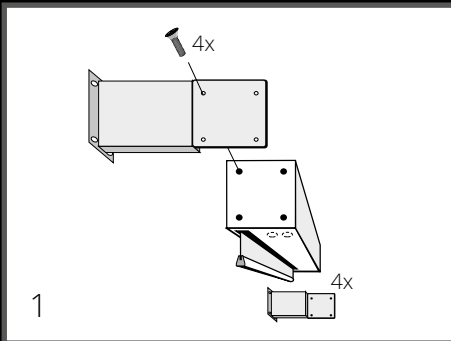

CEILING MOUNTING

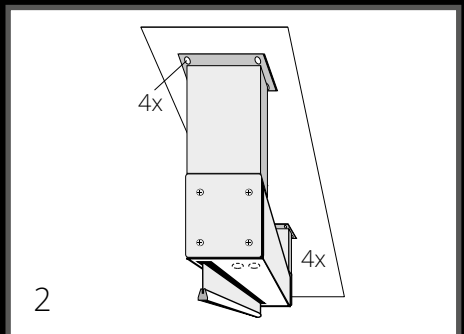
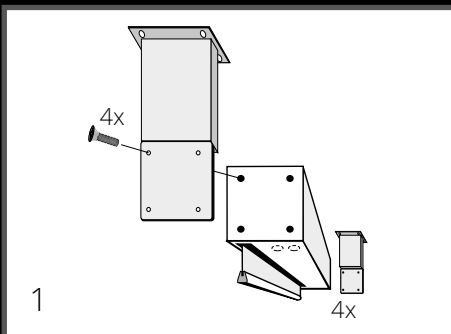

WALL BRACKETS

inline 90^{bm} inline 125^{bm}

inline tensioned 125^{bm}

The INLINE-WALL BRACKETS can be placed at any point on the case. Continuous T-slots on the top provide maximum flexibility of mounting. Available for INLINE 090 and INLINE 125.

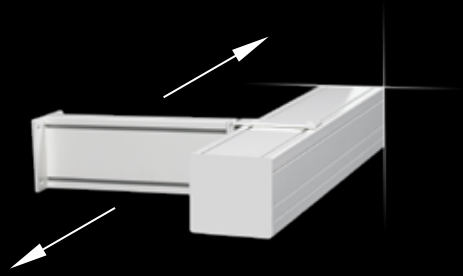

WALL MOUNTING

Each of the two INLINE-WALL BRACKETS have to be attached at the screen casing with the 2 enclosed Phillips screws and 2 square nuts M5 for the T-slots. (see sketches below)

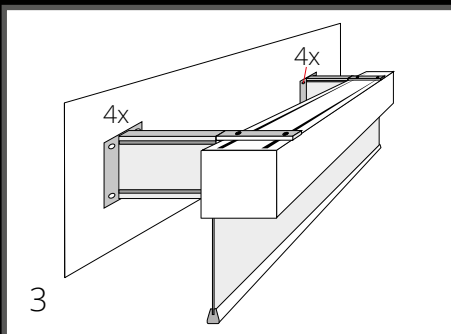
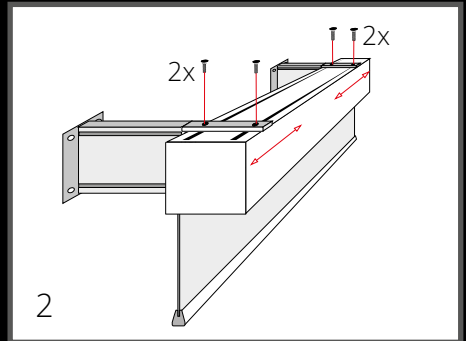
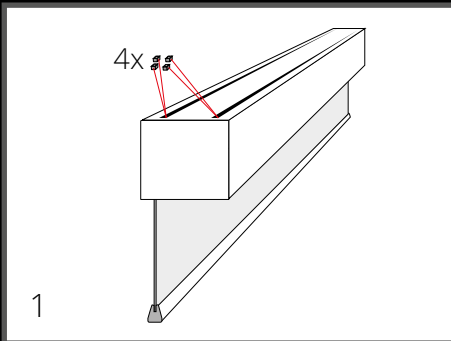

CEILING BRACKETS

inline 90^{bm} inline 125^{bm}

inline tensioned 125^{bm}

The INLINE-CEILING BRACKETS can be placed at any point on the case. Continuous T-slots on the top provide maximum flexibility of mounting. Available for INLINE 090 and INLINE 125.

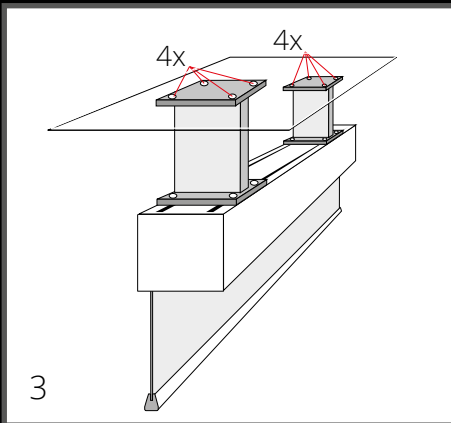
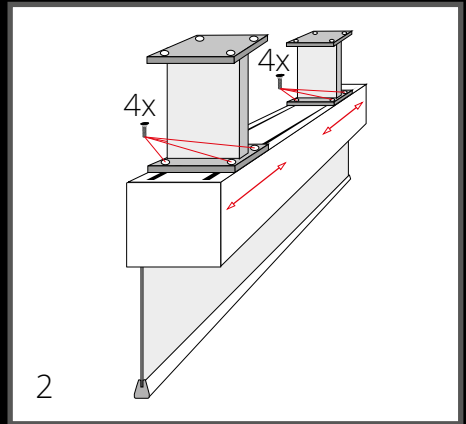
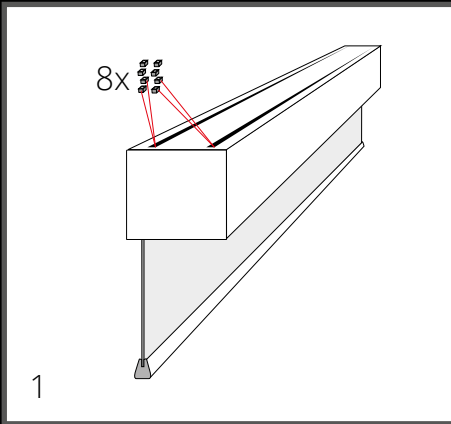
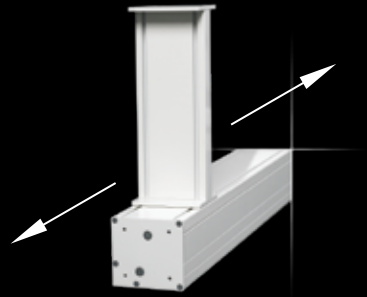

CEILING MOUNTING

Each of the two INLINE-CEILING BRACKETS have to be attached at the screen casing with the 4 enclosed Phillips screws and 4 square nuts M5 for the T-slots. (see sketches)

CEILING CASE FOR CEILING INTEGRATION

CEILING CASE without MOUNTING SET



The CEILING CASE can be pre-installed during building works and the screen installation can be done after building works are completed. Mounting without thread rods, the case is screwed directly to the concrete ceiling at the connecting plates (red). (see figure)

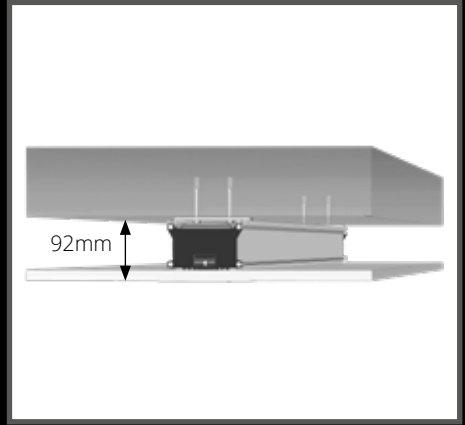
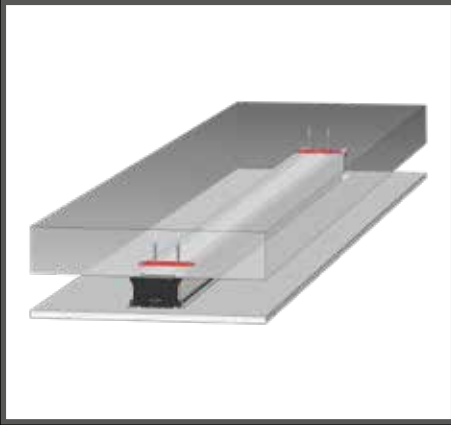

The installation height is only 92mm!

CEILING CASE with MOUNTING SET

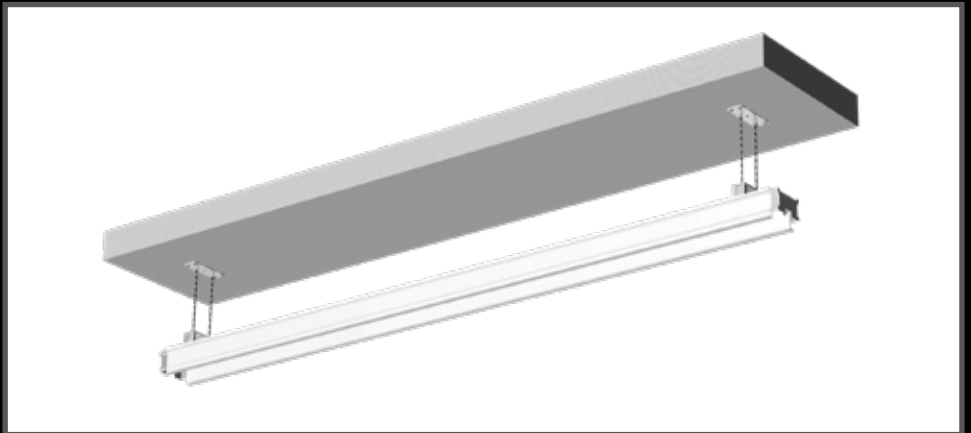

CEILING CASE with MOUNTING SET

inline 90sm

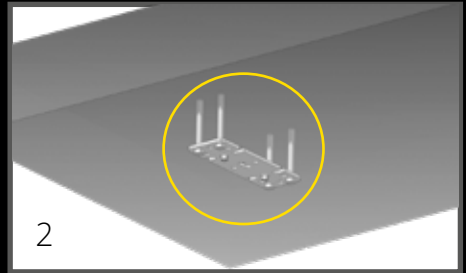
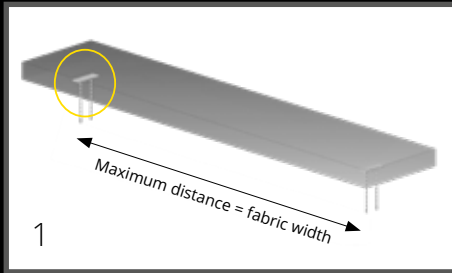

1-2: Parallel and aligned mounting of the two ceiling plates with four screws each.
(maximum distance = fabric width)

NOTICE

Please choose screws which are suitable for the weight of the CEILING CASE with the roll-up screen and for the wall characteristics.

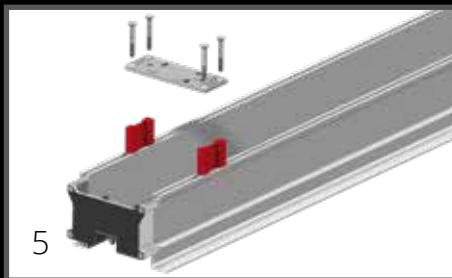
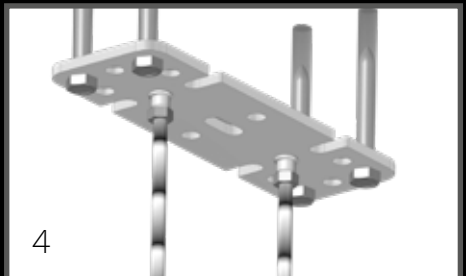
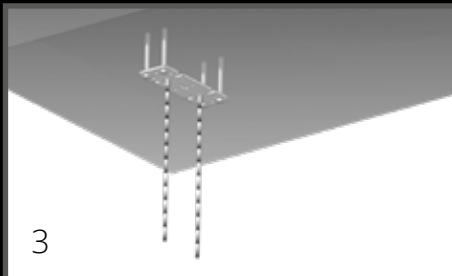

3-4: Screw in the thread rods into the appropriate thread inserts against the concrete ceiling and secure them with the counter nuts. The thread rods have to be shortened in a length of 100mm less than the distance between concrete ceiling and lower edge of the suspended ceiling.

5: Mounting with thread rods:
The distance elements (red) have to be attached between the CEILING CASE and connecting plates. Please detach the left and right connecting plate, and position them centered in the distance of the thread rods. Therefore use the enclosed longer countersunk screws.

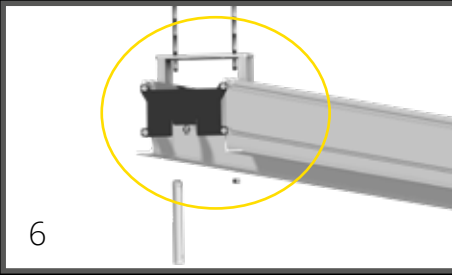

6

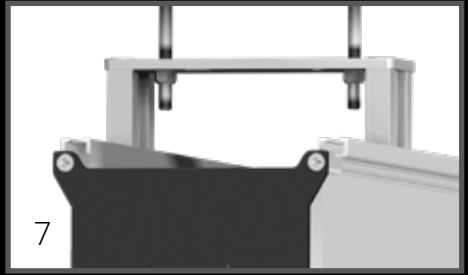

7

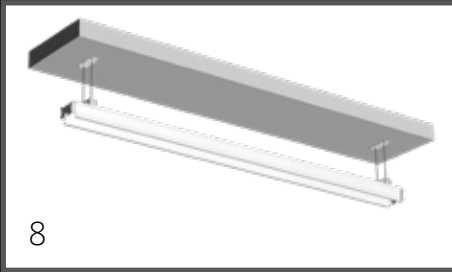

8

6-8: The CEILING CASE is to be adjusted to the intended level of the suspended ceiling by four safety nuts M5. Therefor make use of the delivered tubular spanner.

NOTICE

Important information for the installation of the suspended ceiling:
 It must be ensured that the CEILING CASE is not compressed, to allow the subsequent installation of the roll-up screen. The CEILING CASE must have a constant opening width of 90.5 mm (3 9/16 inch) over the entire length to prevent a jamming of the bottom bar of the roll-up screen.

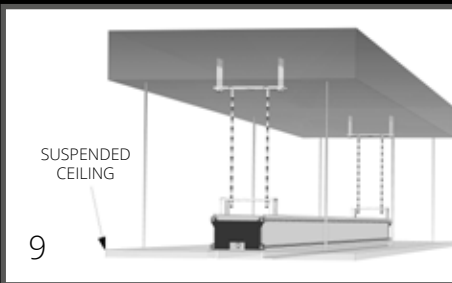

9



In case of a subsequent mounting a recess according to the sketch above has to be made.
 overall length = fabric width + 152 mm

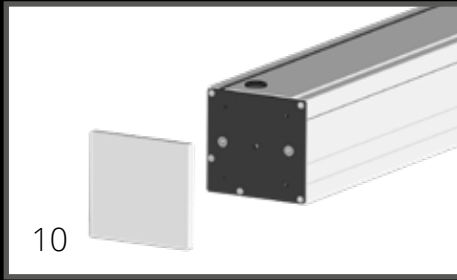

10

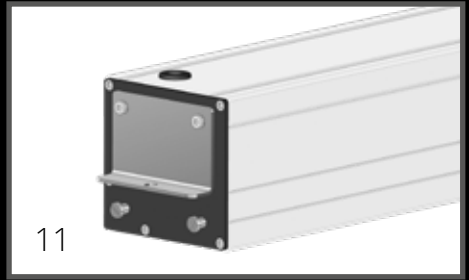

11

Roll-Up screens in Quick-Mount version have to be adapted to fit into the CEILING CASE.(10-12).

1. Detach the lateral case covers (10).

2. Attach the mounting brackets on both side panels as shown on picture (11).

3. Two flat head screws have to be screwed to each side panel according to the sketch, to enable the attachment of the lateral clip brackets (11).

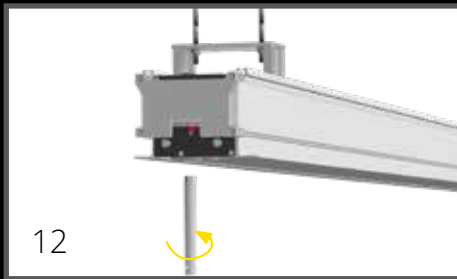

12

12: The projection screen is then attached on each of the two thread bolts in the CEILING CASE with a washer and a lock nut (red). Please make use of the tubular spanner again.

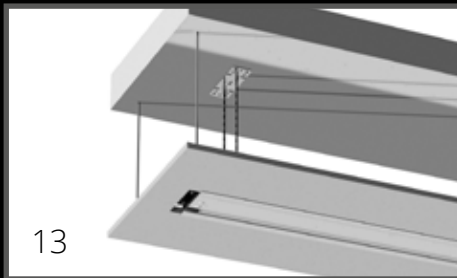

13

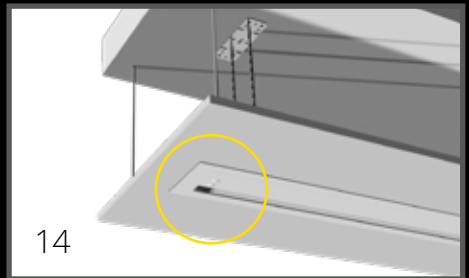

14

13-14: Finalizing, the two lateral gaps are closed with the clip brackets.

PROJECTION SCREEN for CEILING INTEGRATION

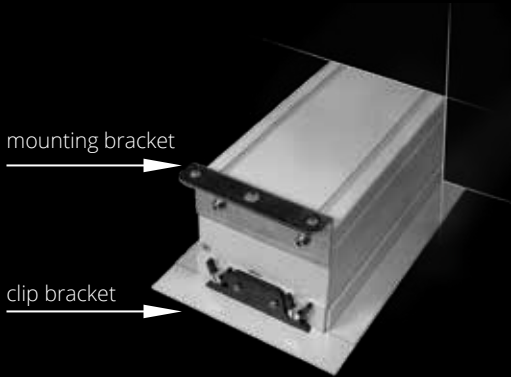

No additional access for servicing needed!
The projection screen can be easily dismounted by taking off the clip covers and detaching the connection at the mounting brackets.

MOUNTING SET for SUSPENDED CEILING

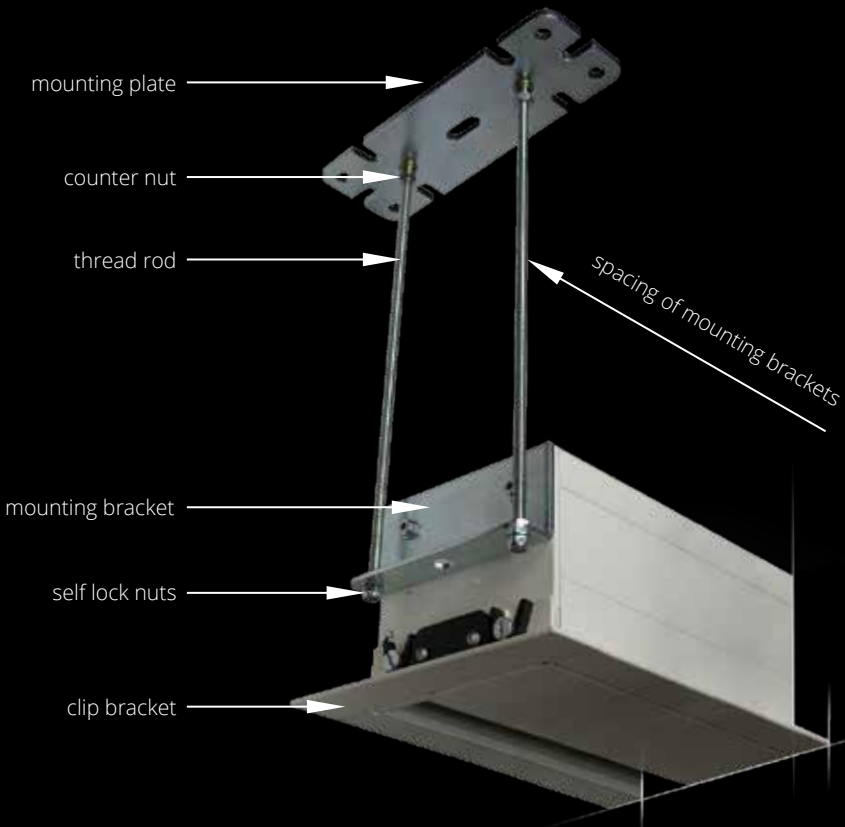

MOUNTING SET for SUSPENDED CEILING

inline 90^{bm}

inline 125^{bm}

inline 160^{bm}

inline tensioned 125^{bm}

inline tensioned 160^{bm}

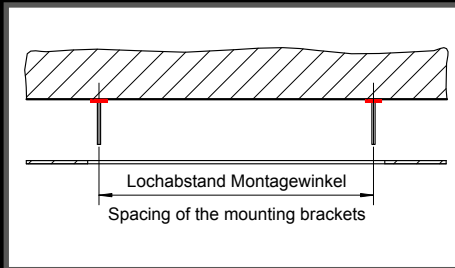

1. MOUNTING PLATES

The mounting plates have to be fixed according to the hole pattern of the projection screen's mounting brackets. (see sketch)

2. THREAD RODS

Screw in the thread rods and shorten them according to the sketch.

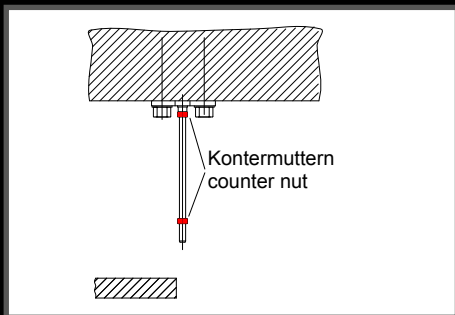
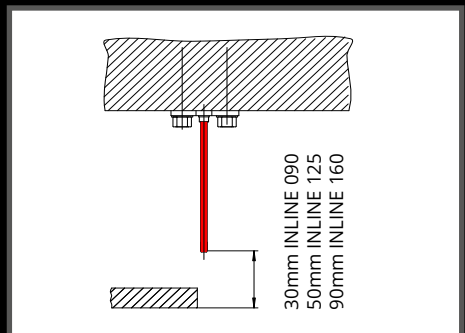

3. COUNTER NUT

Screw on a counter nut on either side of the thread rods. Screw in the thread rods against the ceiling and secure them with the counter nuts.

4. MOUNTING OF THE PROJECTION SCREEN

The roll-up projection screen is to be adjusted to the intended level of the suspended ceiling by four safety nuts M5. Use the delivered tubular spanner. After adjustment secure the screen with the upper counter nuts.

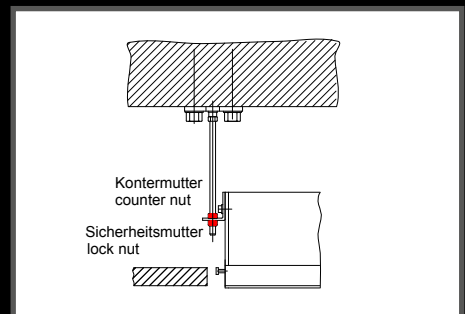

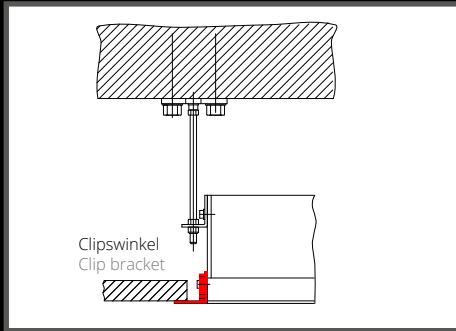

5. CLIP BRACKET

Final work will be to close the two lateral gaps with the clip brackets.

RECESS FOR SUSPENDED CEILINGS

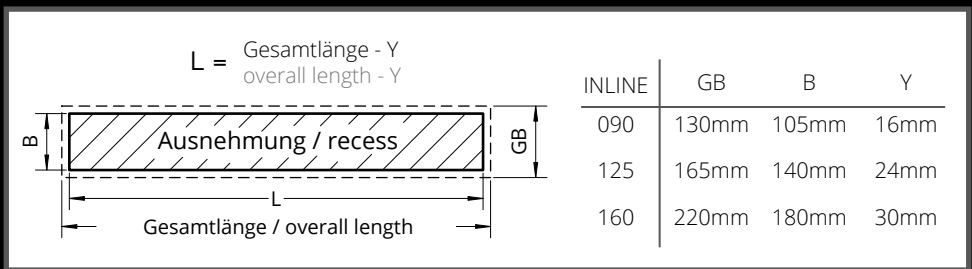

In case of subsequent mounting of the projection screen into a suspended ceiling, a recess L x B according to the screen type has to be made (see sketch above)

ELECTRICAL INSTALLATION

ELECTRIC SUPPLY

230VAC 50Hz. Line circuit breaker 10 A. Motor cable 4x0,75mm²



The electrical installation has to be done by an authorized electrical enterprise. Please hand over this information and the wiring regulations, enclosed to each motor and switch or control unit, to the responsible electrician.

SINGLE CONTROL-230V (See circuit diagram)

NOTICE

Incorrect control of the tube motor results in electrical overload on the limit switches and may change the set stop positions. In extreme cases the limit switches may get welded together permanently. This causes the motor to be permanently activated and the projection screen to be damaged.

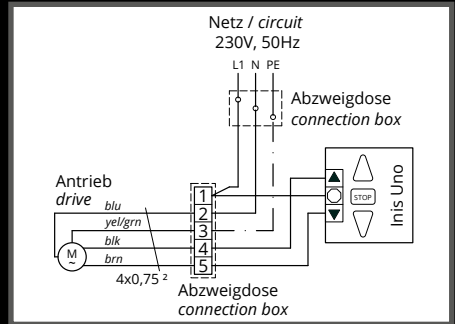

IN ORDER TO AVOID AN ELECTRICAL OVERLOAD OF THE LIMIT SWITCHES IN THE TUBE MOTOR, THE WIRING AND THE CONTROL COMMANDS ,MUST COMPLY WITH THE FOLLOWING REGULATIONS:

1. DO NOT RUN TWO OR MORE MOTORS IN PARALLEL FROM ONE OUTPUT.

A separate contact must be available for every drive and running direction.

2. SWITCHES AND CONTROLS MUST NOT ALLOW SIMULTANEOUS UP-AND DOWN COMMANDS.

Simultaneous up and down commands cause a short-circuit of the operating capacitor.

For that reason only electrically or mechanically locked single switches (no light switches) must be used.

3. THE CHANGEOVER-DELAY BETWEEN UP AND DOWN COMMAND MUST BE 500MS AT LEAST.

Switching periods under 0,5s results in extremely high currents, which may result in the limit switches being welded together and therefore the projection screen being damaged.

NOTICE

OPERATION VIA A MEDIA CONTROL SYSTEM (DRY CONTACT)

In order to control a roll-up screen via a media control system a motor control unit must be installed! Any damage to the motor and consequential damage caused by non-integration of a motor control unit are excluded from the warranty.

Motor control unit-> See chapter "Accessories"

Incorrect connection of the projection screen may damage the motor!

STOP POSITION ADJUSTMENT

NOTICE

LOSS of WARRANTY

The projection screen is properly adjusted at factory and the adjusting screws are sealed. Changing of the minimum or maximum final position is not necessary.

Important: Any damage caused by the adjustment of final positions is not covered by warranty.

Note: Should it be necessary to adjust the final positions by applicational reasons, only skilled personnel is allowed to do so.

Do the adjustment in small steps (one-quarter turn) and check the result by unwind and rewind the fabric completely.

NOTE

Tube motors are not suitable for permanent operation; maximum power-on time is 3 - 4 minutes.

When the roll-up screen is running any longer than that, a thermal circuit breaker switches off the motor. In such a case you need to wait for about 15 minutes before the motor is ready for operation again!

STOP POSITION ADJUSTMENT

MOTOR LEFT/FABRIC BACK AND MOTOR RIGHT/FABRIC FRONT

ADJUSTING THE LOWER STOP POINT MAX OF THE TUBE MOTOR :

Remove the round cover cap at the bottom of the screen casing (see Fig. MAX).



IN ORDER TO MOVE THE STOP POINT MAX UP YOU NEED TO TURN THE WHITE SET SCREW TO THE RIGHT (CLOCKWISE) (SEE FIG. MAX)



IN ORDER TO MOVE THE STOP POINT **MAX** DOWN YOU NEED TO TURN THE WHITE SET SCREW SLIGHTLY TO THE LEFT (COUNTER-CLOCKWISE) (SEE FIG. MAX)

NOTICE

The STOP mark must not be visible! There is a risk of the projection screen material is ripped off the winding tube and irreparable damage being caused.

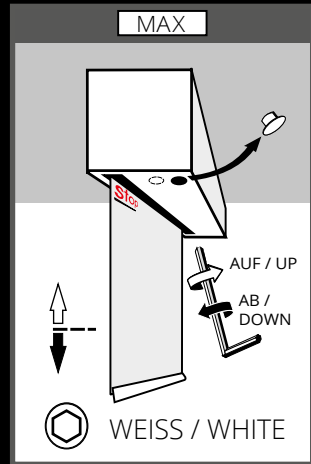

ADJUSTMENT OF THE FINAL POSITION MIN:

Remove the round cover cap at the bottom of the screen casing (see Fig. MIN).



IN ORDER TO MOVE THE STOP POINT **MIN** SLIGHTLY UP YOU NEED TO TURN THE YELLOW SET SCREW SLIGHTLY TO THE LEFT (COUNTER-CLOCKWISE) (SEE FIG. MIN).



IN ORDER TO MOVE THE STOP POINT **MIN** DOWN YOU NEED TO TURN THE YELLOW SET SCREW TO THE RIGHT (CLOCKWISE) (SEE FIG. MIN).

NOTICE

The STOP mark must not be visible! There is a risk of the projection screen material is ripped off the winding tube and irreparable damage being caused.

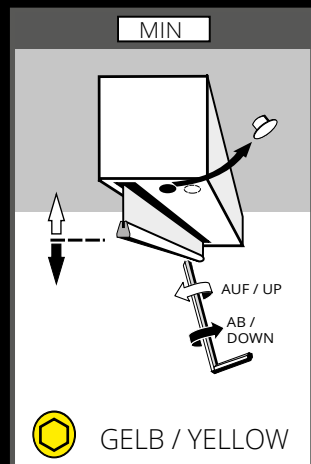

CAUTION

The screen material and/or the bottom bar falling down may cause injuries to persons within the danger area below the projection screen.

STOP POSITION ADJUSTMENT

MOTOR LEFT/FABRIC FRONT AND MOTOR RIGHT/FABRIC BACK

ADJUSTMENT OF THE FINAL POSITION MAX:

Remove the round cover cap at the bottom of the screen casing (see Fig. MAX).



IN ORDER TO MOVE THE STOP POINT **MAX** UP YOU NEED TO TURN THE YELLOW SET SCREW TO THE RIGHT (CLOCKWISE) (SEE FIG. MAX)



IN ORDER TO MOVE THE STOP POINT **MAX** DOWN YOU NEED TO TURN THE YELLOW SET SCREW SLIGHTLY TO THE LEFT (COUNTER-CLOCKWISE) (SEE FIG. MAX)

NOTICE

The STOP mark must not be visible! There is a risk of the projection screen material is ripped off the winding tube and irreparable damage being caused.

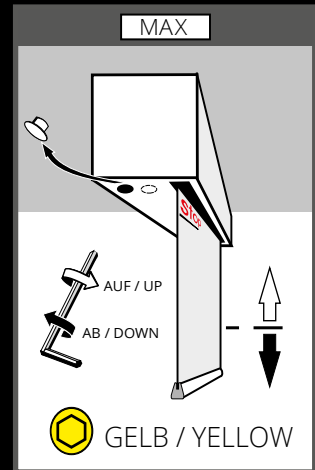

ADJUSTMENT OF THE FINAL POSITION MIN:

Remove the round cover cap at the bottom of the screen casing (see Fig. MIN).



IN ORDER TO MOVE THE STOP POINT **MIN** SLIGHTLY UP YOU NEED TO TURN THE WHITE SET SCREW SLIGHTLY TO THE LEFT (COUNTER-CLOCKWISE) (SEE FIG. MIN).



IN ORDER TO MOVE THE STOP POINT **MIN** DOWN YOU NEED TO TURN THE WHITE SET SCREW TO THE RIGHT (CLOCKWISE) (SEE FIG. MIN).

NOTICE

The bottom bar of the screen material must not be pulled into the opening of the screen casing! There is a danger that the bottom bar will be ripped off from the screen material and falls down.

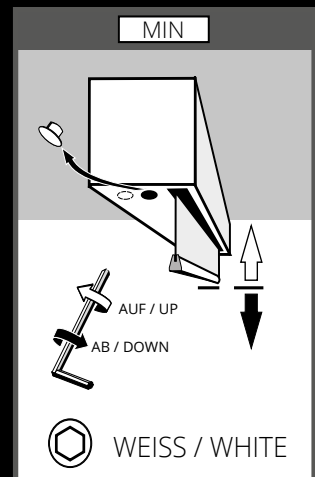

⚠ CAUTION

The screen material and/or the bottom bar falling down may cause injuries to persons within the danger area below the projection screen.

ACCESSORIES

CONTROL OF ONE MOTOR



BRZ-S-SW-SMO-UNO

Wall switch, for single motor control (UP-STOP-DOWN), flush mounted (surface mount adapter optional available)



BRZ-S-SW-KEY-UPAP

Key switch, for single motor control (UP-STOP-DOWN), surface and flush mount optional

MEDIA CONTROL (DRY CONTACT)



BRZ-S-MC-SMO-UNO-IB

Motor control unit for flush mounting with integrated switch, 2 intermediate positions programmable, surface mount adapter optional available



BRZ-S-MC-CD1X1N

Motor control unit, with dry contacts and with safety insert to protect the motor from impermissible control commands (version for mounting on a 35mm DIN rail in distribution cabinets), additional switch control possible

MEDIA CONTROL AND RADIO CONTROL (DRY CONTACT)



BRZ-S-RC-INT-IB-RTS

1-channel wireless wall transmitter for installation in a standard flush-mounted box. Dry contact inputs for operating a roll-up screen with a media control panel.

RADIO CONTROL



SOMFY RADIO CONTROL-SET (BRZ-S-RC-SET-IWR-SIT)
Consisting of In-Wall Receiver RTS for flush mounting and remote control Situo 1 (optional: Situo 5 ... five channels), flush mounting (surface adapter optionally available)



SOMFY RADIO CONTROL-SET (BRZ-S-RC-SET-IWR-SMO)
Consisting of In-Wall Receiver RTS for flush mounting and remote control Smooove 1 Origin RTS for wall mounting

TRIGGER



TRIGGER 12V (BRZ-S-TRIGGER-12V)
For controlling the projection screen via a projector with trigger output, direct control of the projection screen via optional switch possible



TRIGGER 230V (BRZ-S-TRIGGER-230V)
For controlling the projection screen via a projector without trigger output, direct control of actuators via optional switches possible

You will find detailed information for our further control options on our website:

www.AVstumpfl.com/rollupcontrol

MANUAL ROLL-UP SCREENS

CRANK MECHANISM

inline 90sm inline 125sm

NOTICE

Do not unwind beyond the STOP-limit! Do not pull the bottom bar into the casing!

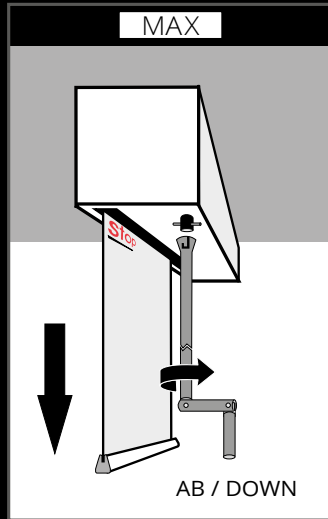
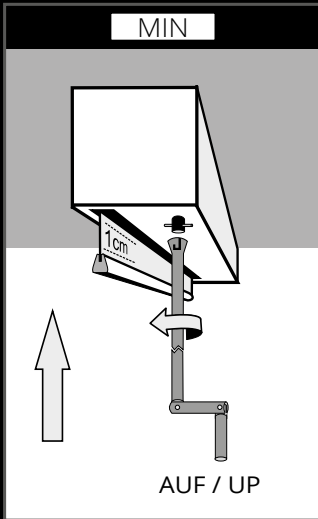

SPRING-ROLLER MECHANISM WITH SOFT-REWIND

inline 90sm

NOTICE

Do not pull down the fabric beyond the STOP-mark!
There is a risk of the projection screen material is ripped off the winding tube or the soft rewind mechanism being locked permanently and irreparable damage being caused.

Unwind:

Guide down the fabric with or without the pull bar on the handle. Stopping the unwind procedure the fabric stays in the respective height after 3 seconds.

Rewind:

Pull down the handle a few centimeters and let the fabric rewind automatically.

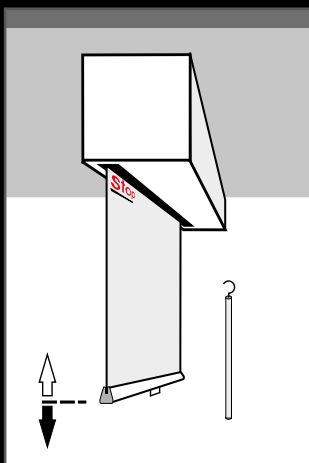

TENSIONING UNIT



Any changes in the room climate (temperature, humidity, winter/summer) may cause the screen material to slightly expand or shrink and result in some sort of waviness near the bottom bar.

Rollup projection screens INLINE and MAGNUM offer the possibility to compensate for these changes by adjusting the tension on the bottom bar.

- 1 Unscrew the two Phillips screws and remove the end caps. Behind these end caps you will find the central set-screw.
- 2 Turning this screw clockwise increases the tensile stress.
- 3 Turning the screw counter-clockwise reduces the tensile stress.

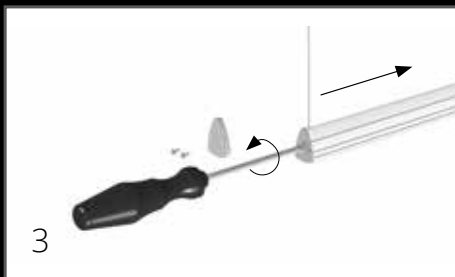
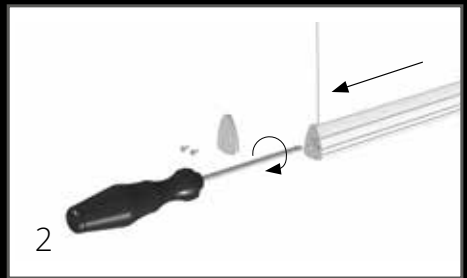
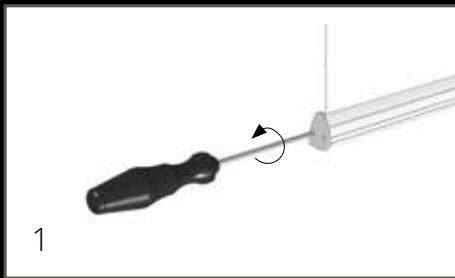

TENSIONING UNIT

inline tensioned tm

Any changes in the room climate (temperature, humidity, winter/summer) may cause the screen material to slight expand or shrink and result in some sort of waviness near the bottom bar.

Rollup projection screens INLINE TENSIONED offer the possibility to compensate for these changes by adjusting the tension of the lateral rubber cords on the bottom bar.

- 1 Detach the screw cover for access to the set-screw.
- 2 Turning this screw clockwise increases the tensile stress.
- 3 Turning the screw counter-clockwise reduces the tensile stress.

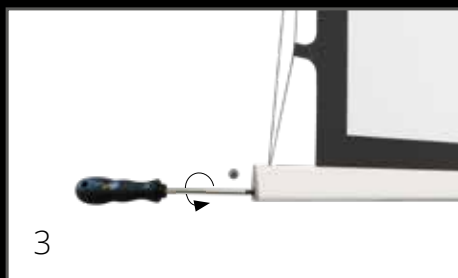
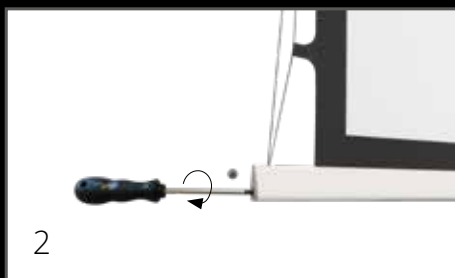
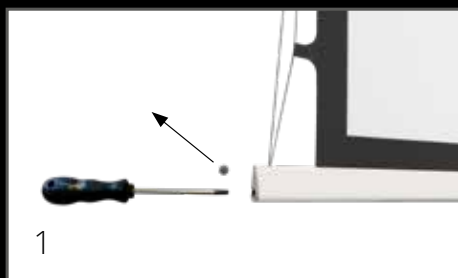

AV Stumpfl GmbH

A-4702 Wallern, Mitterweg 46

Tel.: +43 07249/42811
Fax: +43 07249/428114
AVstumpfl@AVstumpfl.com
www.AVstumpfl.com



Declaration of Conformity

for product lines named as follows

INLINE 90
INLINE 125
INLINE 160

INLINE 125 Tensioned
INLINE 160 Tensioned

MAGNUM 210
MAGNUM 300
MAGNUM 360

We declare that these products are in accordance with the standards and provisions of the applicable directives.

EUROPEAN STANDARDS AND DIRECTIVES:

Machinery directive	DIRECTIVE 2006/42/EC OF THE EUROPEAN PARLIAMENT AND OF THE COUNCIL of 17 May 2006 on machinery, and amending Directive 95/16/EC (recast)
DIN 13501-1	Fire classification of construction products and building elements - Part 1: Classification using data from reaction to fire tests
DIN 19045	Projection of still pictures and motion-pictures
DIN 56950-4	INLINE Entertainment technology- Machinery installations- Part 4: Safety requirements for serially manufactured projection screens
DIN 17206	MAGNUM Entertainment technology - Machinery for stages and other production areas - Safety requirements and inspections; German version EN 17206:2020 + AC:2021



Tobias Stumpfl
Managing Director

AV Stumpfl GmbH

A-4702 Wallern, Mitterweg 46

Tel.: +43 07249/42811
Fax: +43 07249/428114
AVstumpfl@AVstumpfl.com
www.AVstumpfl.com



Declaration of Conformity

for product lines named as follows

INLINE 90
INLINE 125
INLINE 160

INLINE 125 Tensioned
INLINE 160 Tensioned

MAGNUM 210
MAGNUM 300
MAGNUM 360

We declare that these products are in accordance with the standards and provisions of the applicable directives.

UK AND EUROPEAN STANDARDS:

Statutory guidance The Supply of Machinery (Safety) Regulations 2008, Updated 26 July 2022

BS 13501 Fire classification of construction products and building elements
Part 1: Classification using data from reaction to fire tests

DIN 19045 Projection of still pictures and motion-pictures

DIN 56950-4 **INLINE**
Entertainment technology- Machinery installations-
Part 4: Safety requirements for serially manufactured projection screens

BS 17206 **MAGNUM**
Machinery for stages and other production areas. Safety requirements
and inspections



Tobias Stumpfl
Managing Director